

INSTALLATION MANUAL

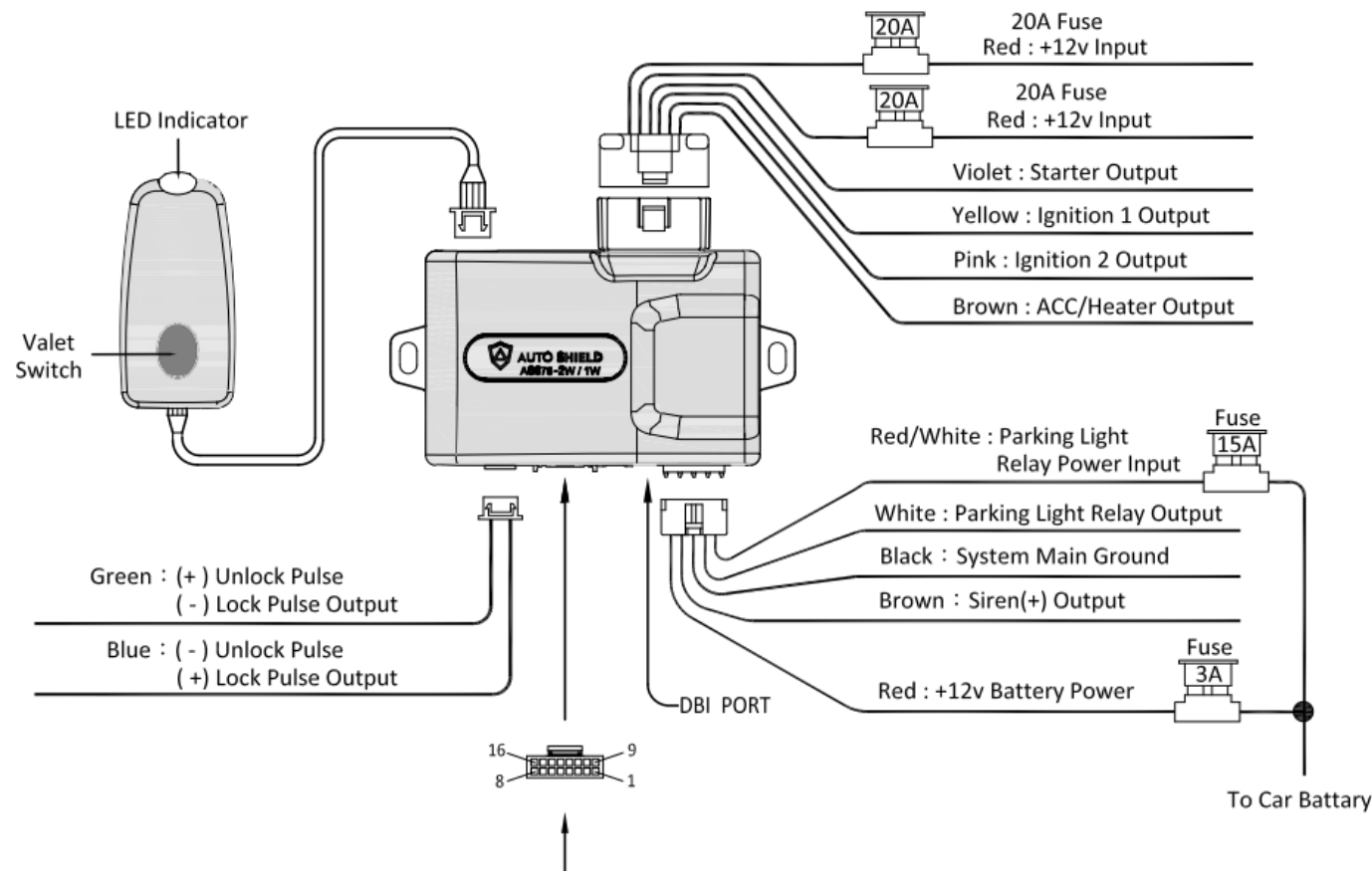

Important Note: The main unit should be securely anchored on a stable surface using zip ties in order for the shock sensor and tilt sensor to work properly.

1	Dark Green	Zone 1 (-) Negative Door Pin Trigger	9	Violet	Zone 1 (+) Positive Door Pin Trigger
2	Dark Blue	Zone 2 (-) Negative Trunk Trigger	10	Orange/ White	(-) 200mA Status Output (Ground Output While Running)
3	Yellow/ Black	(-) Remote Start Activation Input (Automatic Transmission) (See Feature 2-06) Or (-) Parking Brake/E-Brake Input (Manual Transmission) (See Feature 3-06)	11	Red/ Black	(-) 200mA Factory Disarm output (See Feature 2-11) Start Status / Key Sensor By-Pass Output / Dome Light / 2-step Door Unlock
4	White	(+) Brake Switch Shutdown Input	12	Violet/ White	(-) 200mA Starter 3 Output
5	Red / White	(-) 500mA Ground Output When Armed	13	Brown/ White	(-) 200mA Accessory 3 Control Output
6	Pink	Tachometer Signal Input	14	Black/ White	(-) 200mA Ignition 3 Control Output
7	Light Blue	Zone 3 (-) Negative Hood Pin Safety Shutdown Input	15	Green/ Black	(-) 200mA Horn Output (See Feature 2-09, 10) Aux 2 latch/ Aux 2 Latched Output & Reset with Ignition ON/ Aux 2 Flex/ Factory Security Arm / Dome Light
8	Light Green	(-) Neutral Safety Switch Input	16	Gray/ Black	(-) 200mA Trunk Output (See Feature 2-07, 08) Aux 1 latch/ Aux 1 Latched Output & Reset with Ignition ON/ Aux 1 Flex / Dome Light / 2-step Door Unlock

- For easy wire installation, it has 3 wire group, Monochrome wire = Input, Color/Black wire = Programmable output, Color/White = Output

Transmitter Programming:

Enter:

1. Turn the Ignition 'switch "OFF/ON" 3 TIMES and stay in "ON" position. Within 15 seconds.
2. Push the Valet switches 3 times and hold in on the 3rd. push. When a long chirp is heard, release the valet switch. You are now in the Transmitter programming mode.

Program:

1. Press any button on transmitter once until the siren responds with a confirming chirp; the first transmitter is now programmed.
 2. Press any button on the second transmitter until the siren responds with a confirming chirp; the second transmitter is now programmed.
 3. Apply the same procedure to program 3rd. and 4th transmitters.
- Exit:** Turn Ignition to "OFF" position or leave it for 15 seconds. 3 long chirps and 3 parking light flashes will confirm exit.

Note: If more than 4 transmitters programmed, the system will only keep the last four.

To Learn the Tach Signal:

1. Press the Valet switch 2 times and hold in on the 2nd.
2. Hold the foot brake and start the vehicle with the key, after 3 seconds, the status LED will flash to confirm a good tach signal.
3. Release the valet switch and foot brake, a chirp and a light flash will confirm the tach signal is learned.

Note: When the tachometer is programmed, the main unit automatically enters the Tachometer Engine Checking Mode.

Shock sensor Programming:

Note: The main unit should be securely anchored on a stable surface using zip ties in order for the shock sensor and tilt sensor to work properly.

1. Turn the Ignition switch on/off 3 times and stay in the **Off** position.
2. Exit the vehicle and close vehicle's doors to program the shock sensor.
3. **Shock sensor fine tune and test mode:** Press and hold buttons + simultaneously until a long chirp is heard, and then release the buttons. The **S 12** text and tone play on LCD transceiver. You are now in the shock sensor fine tune and test mode.
4. **Auto Learning Mode:** To set sensitivity through shock sensor learning:
 - Press buttons + simultaneously two times and Hold down second time until two long chirps are heard, and then release the buttons. The **0000** text and tone play on the LCD transceiver You are now in the **auto learning** mode.
 - **Hit the car with your fist:** a chirp will be heard to confirm the shock sensor sensitivity has been set. Now you can fine tune and test the shock sensor as needed.

5. Make fine tune to the instant trigger:

- To increase sensitivity, press the transmitter Button,
- To decrease sensitivity, press the transmitter Button.

Note: A chirp will sound to confirm the press, 2 chirps will sound to notify setting at the end.

6. To make fine tune to warn away trigger:

- To increase sensitivity, press the transmitter button,
 - To decrease sensitivity, press the transmitter button.
- Note:** A chirp will sound to confirm the press, 2 chirps will sound to notify setting at the end.



7. Testing the shock Sensor:

- Under programming mode, you can test the shock sensor any time.
 - While testing, a short chirp will sound when the warn-awaysystem is triggered; a long chirp will sound when shock sensor is triggered.
- 8. Exit:** There is no activity for 60 seconds / Turn the ignition switch on will exit program mode and 3 long chirps to confirm exit.

Note:

- Sensitivity level for the shock sensor trigger is from 1 to 27 with 1 being the least sensitive and 27 being the most sensitive.
- Warn-away system's sensitivity settings changes with the shock sensor trigger's sensitivity settings automatically. Therefore sensitivity levels for the shock sensor trigger should be set before sensitivity levels for the warn-awaysystem. The sensitivity range of the warn-away system is from 27 to the shock sensor trigger's sensitivity level with 27 being the most sensitive.
- Please be careful as not to damage the vehicle during the sensitivity adjustments.

Feature Configuration Programming:

1. Turn the Ignition 'switch "On/Off" 3 times and stay in the "Off" position.
2. Press and hold the valet/override button until a long chirp is heard, then release the valet/override switch. You are now in the feature programming mode.
3. Select a Feature bank. Press and release the  button the number of times corresponding to the feature bank you wish to change. The system will chirp to match the feature number.
4. Use the transmitter  button to scroll through the selections in each feature, the system will chirp to match the feature number.
5. Press the transmitter  button to change the desired feature (Opt.), the system will chirp to match the Opt. feature number.

EXIT: Turn the ignition on or there is no activity for 60 seconds, it will exit the setting, a long chirp from siren to confirm,

Back to Factory Setting: Pressing and hold  button for 3 seconds to resets the feature to the factory default.

Feature Bank 1 (1 Chirp) - Security Feature

	Feature	Opt. 1 1 chirp	Opt. 2 2 chirps	Opt.3 3 chirps	Opt. 4 4 chirps	Opt. 5+ 5+ chirps
1-01	Security	Remote Start w/ Security	Remote Start w/ Keyless Entry			
1-02	Data protocol	A.D.S.	Fortin			
1-03	Horn Chip Duration	Standard 20ms	50mS	30mS	10mS	
1-04	Confirmation Chip	Lock & Unlock	Lock Only			
1-05	Factory Alarm Disarm	With Aux 1 On	Without This Feature			
1-06	Door Ajar Error Chip	45 seconds Delay	Instant			
1-07	Siren / Horn Confirmation Chirp	ALL	Siren Only	Horn Only	OFF	
1-08	System Arming Mode	Active	Passive Arming Without Locking	Passive Arming W/ Passive Locking		
1-09	Automatic Rearm	OFF	ON			
1-10	Override Password Pin Code	Setting for 1	Setting for 2	Setting for 3	Setting for 4	Setting for 5 / 6 / 7 / 8 / 9
1-11	Tilt Sensor Adjust and Test Mode	3°	1.5°	Off		

Testing Tilt Sensor: Under Tilt Sensor Adjust and Test mode, you can test the Tilt sensor anytime. The parking light will turn on when tilt sensor is triggered

Feature Bank 2 (2 Chirps) - Convenience Feature

	Feature	Opt. 1 1 chirp	Opt. 2 2 chirps	Opt.3 3 chirps	Opt. 4 4 chirps	Opt. 5+ 5+ chirps
2-01	Door Lock & Unlock (second)	0.8 second	3.5 seconds	0.8 sec. Lock & 0.35 sec. Unlock	0.8 sec. Double Lock & Unlock	0.8 sec. Lock & 0.8 sec. Double Unlock
2-02	Ignition Control Locks	Door Lock & Unlock	Door Lock Only	Door Unlock Only	Without This Feature	
2-03	Dome Light	Turn On & Off After Ignition On & Off	Turn On After Ignition Off	Without This Feature.		
2-04	Parking Light (Pathway Illumination)	OFF	Turn ON For 30 sec. Upon Unlock Signal	Turn ON For 30 sec. Upon Unlock Signal and 10 sec. Upon a Lock Signal		
2-05	Door Unlock Upon Remote Start	OFF	Pulse the Yellow Ignition 1 wire Before Unlock			
2-06	Yellow/ Black Wire (16 Pin Connector)	Activation Pulse Count OFF	Activation Pulse Count 1	Activation Pulse Count 2	Activation Pulse Count 3	
2-07	Gray/ Black Wire (16Pin Connector)	Trunk Output (1 second pulse)	Aux 1 Latched Output	Aux 1 Latched Output & Reset with Ignition ON	Aux 1 Flex 1 sec. (Set interval between 1 to 90 sec.)	5 Dome Light Output 6 2-step Door Unlock Output
2-08	AUX 1 Output	Control by Remote	Control by Arm	Control by Disarm	Control by Arm & Disarm	Control by Remote Start Only
2-09	Green/ Black (16 Pin Connector)	Horn Output	Aux 2 Latched Output	Aux 2 Latched Output & Reset with Ignition ON	Aux 2 Flex 1 sec. (Set interval between 1 to 90 sec.)	5 Factory Alarm Arm Output 6 Dome Light Output
2-10	AUX 2 Output	Control by Remote	Control by Arm	Control by Disarm	Control by Arm & Disarm	Control by Remote Start Only
2-11	Red/ Black Wire (16Pin Connector)	Factory Security Disarm Signal Output	Start Status Output (Bypass the Factory Alarm Shock Sensor)	Key Sensor By-Pass Output (when remote start is activated and stays on for 20 seconds.)	Dome light Output	2-step Door Unlock Output
2-12	Brown Wire (5 Pin Connector)	(+) Constant Siren Output	(+) Pulse Output for Horn (Relay required)	(+) Dome light Output (Relay required)	2-step Door Unlock Output (Relay required)	
2-12	Thick Pink Wire (6 Pin Thick Connector)	Ignition 2 Output	Start 2 Output	ACC 2 Output		

Flex Timer Setting:

System in 2-07 / 2-09 Flex timer program mode.



1. For timer setting less than 10 seconds -- Press and release the valet switch number of times corresponding to the timer you wish to set. (e.g. 1 second = 1 time, 5seconds = 5 times)
2. For Timer setting more than 10 seconds -- Press and hold the valet switch, the timer will start immediately.
3. When the desired interval has passed, release the valet switch.

Feature Bank 3 (3 Chirps) - Remote Star Feature

	Feature	Opt. 1 1 chirp	Opt. 2 2 chirps	Opt.3 3 chirps	Opt. 4 4 chirps	Opt. 5+ 5+ chirps
3-01	Engine Checking Mode	Voltage	Tachometer	Timer Only	Data Bus	
3-02	Starter Release for Tach & Voltage mode	Normal	Low Level	High Level		
3-03	Cranking Time for Voltage and Timer mode	0.6 second	0.8 second	1.0 second	1.2 seconds	5 / 1.4 sec. 6 / 1.6 sec. 7 / 1.8 sec. 8 / 2.0 sec. 9 / 3.0 sec. 10 / 4.0 sec.
3-04	Remote Start Runtime	20 minutes	3 minutes	10 minutes	30 minutes	45 minutes
3-05	Running time interval	3 hours	2 hours			
3-06	Transmission Mode	Automatic	Manual			
3-07	Engine Type	Gasoline	Diesel Engine 10 sec. Warm-Up	Diesel Engine 15 sec Warm-Up	Diesel Engine 20 sec. Warm-Up	Diesel Engine 45 sec. Warm-Up
3-08	Press to Start	Press the  button once	Press the  button twice			
3-09	Parking Light Output Upon Remote Start	Constant	Flashing			
3-10	Door Lock	After Start (Run)	After Shut-Down	Before Start & after Shut-Down	Without This Feature	
3-11	Turbo Mode	No Turbo Mode	Turbo timer 1 minute	Turbo timer 3 minutes.	Turbo timer 5 minutes.	

Shutdown Diagnostics:

The unit has the ability to report the cause of the last shutdown of the remote start system.

Press Buttons  +  simultaneously for 2 seconds.

4 Button Remote Transmitter: The parking light and chirps will now report the reason of the system last shutdown by flashing in the following grouped patterns,

GROUP 1 (One Flash of Parking Light)		
Chirps	Shutdown Mode	Solution
1	Hood Open	<ul style="list-style-type: none"> • Close the hood. • Check 16-pin LightBlue wire connection.
2	Optional Enable Switch OFF or Light Green wire must have a ground	<ul style="list-style-type: none"> • Check 16-pin LightGreen wire connection. • Move the Enable Toggle Switch to "ON" position. (If installed.) Move the gear selector to "Park/ "NEUTRAL" position
3	Foot Brake on	<ul style="list-style-type: none"> • Check 16pin White wire connection • Release Foot Brake.
4	System is in Valet Mode	Exit the Valet mode
5	Hi Voltage (Voltage Checking Type)	Set the "Feature 3-02 to "Low Level"
	Low or No RPM (Tachometer Checking Type)	<ul style="list-style-type: none"> • Check 16-pin Pinkwire connection • Set the "Feature 3-02 to "Hi Level" • Re-learning the RPM
6	The engine has run successfully but is still starting (Tachometer Checking Type)	Set the "Feature 3-02 to "Low Level"

GROUP 2 (Two Flashes of Parking Light)		
Chirps	Shutdown Mode	Solution
1	Alarm triggered	Disarm or Reset Alarm
2	Running Time expired	
3	Transmitter Shutdown	
4	Over-Rev Shutdown	
5	Wait-to-start input timed out	See the Feature 3-07 (For Diesel Engine Only)

GROUP 3 (Three Flashes of Parking Light)		
Chirps	Shutdown Mode	Solution
1	Manual transmission mode is enable and not initialized	Follow the manual transmission setup steps (page 14 of the user manual)
2	Door Open	<ul style="list-style-type: none"> • Close the Door. • Check 16-pin Dark Green or Violet wire connection.
3	(-) Parking Brake / E-Brake in Shutdown	<ul style="list-style-type: none"> • Set the Parking Brake / E-brake • Check 16-pin Yellow/ Black wire connection.
4	No RPM or The vehicle's clutch bypasses fail.	<ul style="list-style-type: none"> • Check 16-pin Pink wire connection • The vehicle's clutch must be temporarily bypassed • Re-learning the RPM